

**Sambandh – Electricity Distribution Utility Services**

Sambandh is an online integrated IT application that uses state of art technologies to provide an entire spectrum of services that an Electricity Distribution Utility should offer to its consumers.

The various stages in the process flow in any Utility Organization to meet its objectives in the Revenue Cycle Management process flow are:

- Connections
- Customer mapping, sequencing and scheduling
- Meter Reading
- Bill Processing
- Bill Printing
- Bill Distribution
- Payment Collection
- Dishonored Cheque Management
- Recovery Follow-up
- Disconnection
- Reconnection
- Surveillance
- Enforcement
- Litigation
- Connection Surrender and account closure
- Energy Audit & Research

Sambandh has been developed to address the requirements of all the stages above. It caters to the requirements of both LT (Low Tension) and HT (High Tension) consumers.

**Sambandh Modules**

Sambandh has nine modules which are designed to cater to the different stages of Revenue Cycle Management.

## Sambandh

## Case Study

### Customer Care Management (CCM)

for addressing customer care requirements

### Connection Management Module (CMM)

for all connection related activities excluding execution

### Meter Management Module (MMM)

for installation / connection, disconnection and replacement of meters and seals

### Meter Reading Module (MRM)

for meter reading management and bill distribution

### Revenue Billing Module (RBM)

for billing, billing correction and quality of bills

### Revenue Collection Module (RCM)

for payment-related activities

### Revenue Recovery Module (RRM)

for recovery of outstanding amount

### Revenue Discipline Module (RDM)

for maintaining discipline in consumers which includes the Legal, Surveillance and Enforcement sub-modules

### Revenue Assurance Module (RAM)

is an administrative module for addressing user maintenance, exception reports, dashboards, and for meeting the regulatory and statutory requirements

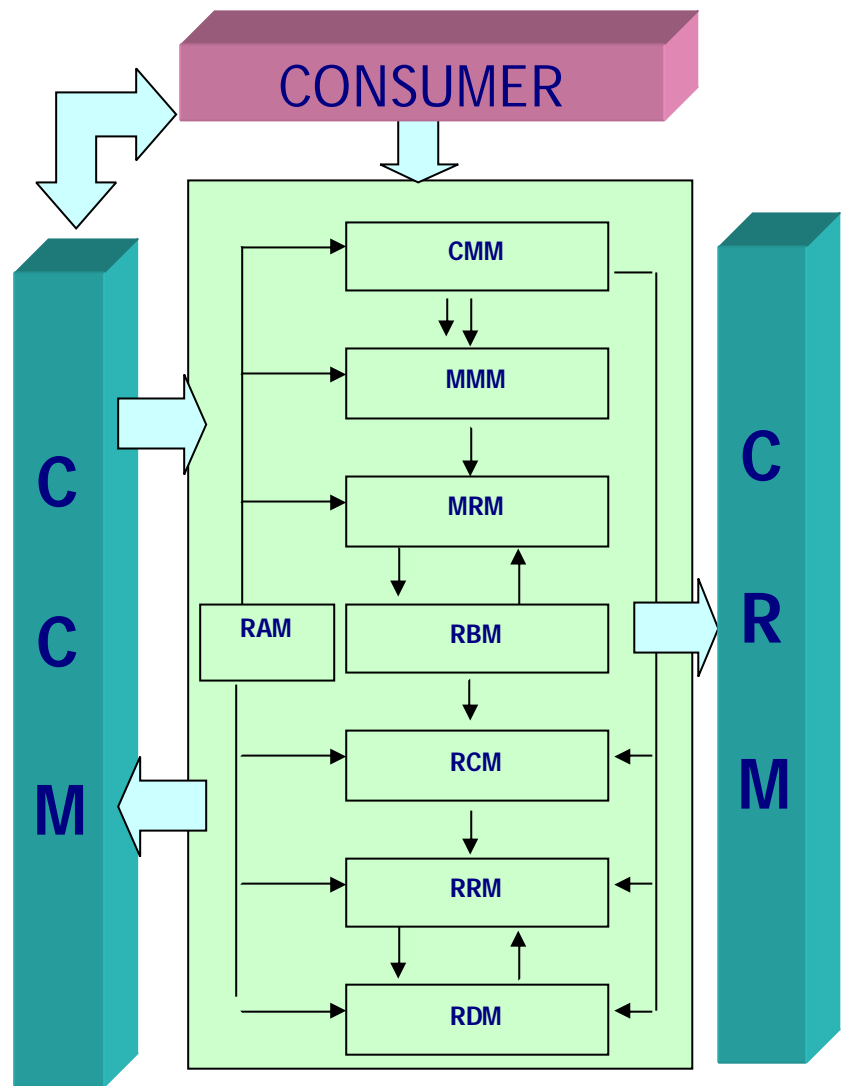

## Stakeholders

The benefits that various stakeholders of Sambandh would derive are

- **Management:** Consistent and correct information, energy accounting, effective monitoring at all levels, data-based decision-making, shorter cycle time leading to quicker realisation of revenue, fewer consumer grievances
- **Users:** One-time data entry eliminating duplicity of work, online data entry validation eliminating data entry errors, flow of information across the various departments seamlessly, faster response to consumers' queries, enables to focus on core activities
- **Consumers:** accurate bills, faster service time, single window service, data-based dispute settlement, user-friendly services through internet, SMS, IVRS, etc.

**Key Features**End-User Perspective

- User-friendly, consistent and standardised man-machine interfaces across sub systems
- Universal counters for all types of applications, all types of payments (energy and non-energy)
- Get information from any counter of the Electricity Distribution Utility located across the city
- Supports online and offline payment collections
- Tariff structure is maintained modularly to take care of any changes in tariff anticipated in future
- Maintains previous and current tariff structures
- Handles rebates and surcharges, arrear surcharge, availability-based tariff
- Tariff maintenance from a central location
- Provides the defined work flows across various departments dealing with consumers
- Option available to support double data entry for cross validations for all types of forms

Implementation Perspective

- Developed using a modular and parameterised approach for easy maintenance
- Provides audit trail of various activities like meter replacements, bounced cheques, load change, category change, billing address changes, name change with arrears, meter reading is maintained in the product
- Common security module
- Provides online help

**Product Architecture**

Sambandh does not have any constraint related to organisation structure of a State Electricity Board belonging to the Indian power sector. The level and hierarchy of these offices will vary from board to board.

The product can be implemented at any of the levels using either of the centralised or decentralised options. However, the architecture will depend upon various other factors like consumer density, local conditions, geographical locations, availability of ISDN/leased line, etc.

Typical product architecture

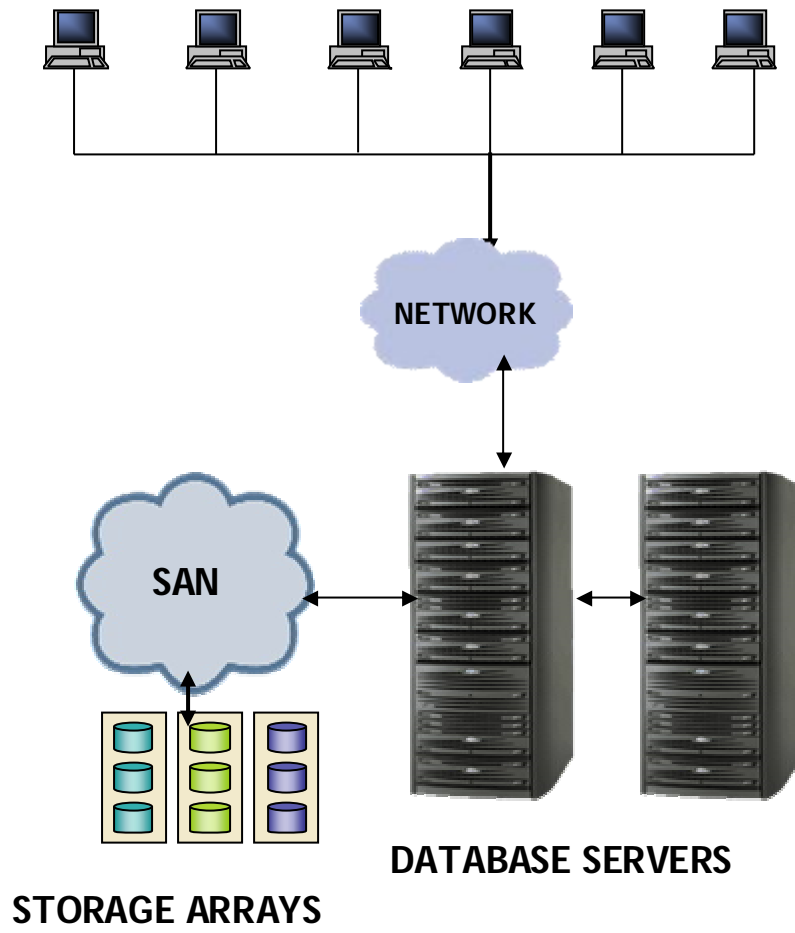

### Functionality/Modules

Sambandh is a modular, application software package, developed using open system architecture. It has following modules, which caters to various functional requirements of electricity distribution utilities.

#### Customer Care Management (CCM)

This module is the front face of the utility and provides for the capture of key information of consumers during calls received from the consumer or calls made to the consumer.

- **In-Bound** – assists in the capturing of
  - Key information of prospective consumers
  - Various complaints of existing consumers related to metering, billing, payments, etc.
- **Out-Bound** - for updating/informing the consumers on
  - Current status of their request/complaints
  - Data provided by the Revenue Recovery Cell to facilitate recovery of outstanding dues from consumers

#### Connection Management Module (CMM)

This module supports functionalities pertaining to new connections, reconnections, attribute changes and connection closure.

The Connection Management process has been designed with the sole objective of providing consumer-centered service to applicants. Primarily, the connection process handled by the Connection Management Module broadly comprises of the following sub-modules:

- **Field Counseling Executive Management** – Allocation of tasks and updation of status to the various field executives based on calls received by CCM Module for new connections
- **CSF (Connection Service Form) Entry** – Entry of filled applications for new connection, reconnection, attribute change, connection closure and miscellaneous application
- **Appraisal Sheet** – Records the clearances required from RCM, RRM and CMM for processing new connection requests
- **Attribute Change** – To change the various billing and non-billing consumer attributes
- **Consumer Clubbing** – To maintain and track relationship between various consumers to ensure billing is on same day. This is useful especially in case of multiple offices of an organisation which are spread across various districts of the utility. Consumer clubbing links all these offices so that they are billed on the same day and a consolidated bill is generated
- **Demand Note Management** – Handles the generation and printing of demand note for new connections
- **Connection Closure** - Connection is closed when user requests for same
- **Consumer Relation** – This helps to establish the relationship between the various consumers such as father and son, etc.
- **Installation Verification Survey** - Maintains the data of consumer installation survey to verify the status of connection for various reasons such as quality checking, random inspections
- **Records Management System**- Stores the location of physical records and scanned images. It displays scanned images as and when required

#### Meter Management Module (MMM)

This module caters to the functionality related to installation / connection, disconnection and replacement of meters and seals. The various sub-modules include:

- **New Connections / Installations**
- **Disconnections**
- **Replacement of Meters and Seals** – Individual / mass replacements
- **Material Management** - Maintains inventory of meters, seals, and other materials such as Bus Bar Boxes, CT/PTs, cables, etc. It provides for recording of
  - Meters received at the stores,
  - Issued from the stores

- details of old / defective meters returned to the stores
- **Protocol Sheet Management** - Generates activity advice related to each meter (installation, replacement, etc.) to be given to the agency and prints the information on specified format. It also enables entry of filled protocol sheets returned by the agencies
- **Meter Recycling** – All removed meters go through inspection and testing desk to decide whether they can be recycled or crushed
- **Meter Testing** – Allocation of tasks for testing of meters to various meter testers and capture of the test results

#### Meter Reading Module (MRM)

This module deals with Indexing of consumers, Meter Reading Management and bill distribution

- **Consumer Indexing**
  - Records the electrical address of each consumer e.g. SS/feeder/DT/Pole
  - Enables for energy auditing at defined level
  - Enables benchmarking the DT/ Feeder/ Sub-station on consumer density and revenue realisation
- **Reading Operations**
  - Assists in creation of cycle-wise / DT-wise reading schedules
  - Interfaces with hand-held computers/MRI/CMRI for uploads and downloads
  - Allows for upload of meter readings from a TXT file in a pre-defined format submitted by third parties / agencies
  - Generates various Exception Reports highlighting possible inconsistencies in the metering data such as high / low consumptions, negative readings, etc.
- **Reading Validations** – The system necessitates validations of readings before billing. It allows to select the reading if the reading is taken multiple times from the premises
- **Reading Modification** – Enables capture of direct readings for NR (Not Read) cases and corrections of wrong reading
- **Bill Distribution** – Facilitates management of bill distribution and enables to record reason for non-delivery of each bill that could not be delivered in various attempt

#### Revenue Billing Module (RBM)

This module deals with consumer billing, billing correction and checking the quality of bills:

- **Bill Processing Management (BPM)**
  - Generates energy bills for
    - Full cycle
    - Within a cycle for
    - DT / book
    - Supply type
    - Connection type
    - Consumer category
    - Consumer
  - Enables generation of different types of bills
    - Normal
    - Provisional / average
    - Adjustment
    - Assessment
  - Allows duplicate bill printing
  - Facilitates Change of due dates
- **Bill Quality Control (BQC)** – Enables stopping of inflated bills, and other wrong bills before generation. Enables BQC during bill processing, printing and distribution by providing for stopping of bills at various stages
- **Bill Installment** – Enables the bill amount to be divided into installments based on user defined amount, user defined percentage, or equated installments
- **Bill Revision** – Deals with the various scenarios for revision of bills such as suspected wrong reading, wrong punching of readings, for faulty meter period, to make payment adjustments, and for slab benefit
- **Billing Report Management** – Generates consumer based bill reports

- **JE Management (JEM)** - Facilitates credit/debit to consumer account for bill corrections by competent authority. These adjustments are applied to next bill. This sub-module maintains details of adjustment/journal entries

Additional features of this module include:

- ✓ Automatic levy of rebates and penalty
- ✓ Bar code printing
- ✓ Billing for seasonal industries
- ✓ Billing across multiple tariff

#### Revenue Collection Module (RCM)

This module deals with payment / collection related activities. The various sub-modules include:

- **Payment Collections** – Enables the collection of
  - Energy bills
  - Non-energy bills
  - Installments / part payments
  - Theft / enforcement bills
  - Advance payment
  - Energy bill for commercial
  - Energy bill for street lights
  - Energy bill for bulk consumers
  - Payments received by other agencies (banks, drop boxes) and POS machines
- **End of the Day** – Deals with day end functions at the individual counters such as:
  - Allows entry of currency-wise domination, and number of cheques, DDs, and credit card payments received
  - Enables transfer of collections from one counter to another
  - Validates / reconciles the collection before counter closure
  - Generates pay-in slips for banks, reports for counter-wise collections
- **Back office operations** – These operations include
  - Cash Counters Management - Enables setting of active / inactive counters for a day
  - Passbook maintenance - Provides for upload/capture the passbook file received from the banks (for honoured / dishonoured cheques). It also provides for entry of miscellaneous transactions (Dr / Cr) into passbook
  - Bank Book Maintenance - Facilitates verification/posting of bank instruments collected; and viewing of counter-wise pay-in slips generated
  - Cash Book Maintenance – Facilitates viewing of the cash collections of a day. It also facilitates verification/posting of cash collected

#### Revenue Recovery Module (RRM)

This module facilitates in the recovery of outstanding amount from the consumers. RRM provides the options to follow up defaulters through call center, field counseling or disconnection notices. This module helps the users in

- Planning and identification of defaulters
- Recovery Call Management
- Letter Management
- Disconnection notice
- Disconnection advice and quality check
- Field counseling

#### Revenue Discipline Module (RDM)

This module helps in maintaining the discipline in consumers. It is divided into 2 main sub-modules:

- **Legal** - The main task of Legal Module is to monitor the court cases and rendering legal advice to the other modules on pending or disposed matter. The system would keep track of various cases filed against or by the utility. The various functions of this module include:
  - Case detail entry
  - Hearing detail entry
  - Stay detail entry
  - Judgment detail entry
  - Compliance detail entry
- **Enforcement** – This module handles the following functions:
  - Surveillance Request Management
  - Generation of provisional and final theft bills

#### Revenue Assurance Module (RAM)

- **Consumer Information System (CIS)** – Displays complete information of a consumer such as connection details (billing and non-billing parameters), meter details, various readings, billing information, etc. through a set of screens
- **Dashboards** – A set of screens for the control room to monitor the status of various on-going activities such as field executive activities and meter reader activities during the day
- **MIS** - For addressing the regulatory and statutory requirements of the utility, this module provides various types of reports

#### Reports

The system caters to more than 100 reports. Some of the major reports include:

- ✓ Energy audit reports
- ✓ Reading validation reports
- ✓ Reading accuracy reports
- ✓ Consumption/bill amount movement matrix
- ✓ Passbook for the company
- ✓ White book/heavy sheet for collection
- ✓ Defaulter analysis
- ✓ Holding company arrears
- ✓ Consumer bill ledger
- ✓ Request movement report
- ✓ Reading and billing schedule
- ✓ Case compliance report

#### **User-Role/Counter-based Security**

To prevent unauthorised users to access the system, a security mechanism is set up to authorise the officers using the system. Following are the key features of user-role based security:

- **Unique User IDs:** Each user has to login with a unique user name and password
- **Limiting multiple logons:** The system limits each user ID to one simultaneous logon session
- **Role based login:** The user is required to login into the system based on a role
- **Counter based login:** System allows the user to login from only those counters from where he has the authority to do so
- **Temporary Locks:** Access to the system after specified timings is prevented
- **Session Information:** System maintains information about the session and associates the details with the transactions made during the session
- **Account Locking:** After a designated number of consecutive unsuccessful attempts to logon to a user ID, that user ID is disabled against further use
- **Application time-out:** Terminal/ user ID time-out occurs if a terminal/ user ID remains logged onto a system/ application but remains inactive for a predefined time
- **Standard user profiles:** System provides a mechanism to build a range of User IDs with a standard user profile of multiple categories

### Checksum Mechanism

Checksum mechanism is used to keep a check on changes made on the billing attributes like connection status code, supply type code, load, etc. This ensures a check against any illegal change made through backend. As these attributes change through application (form) i.e., the proper change, the history tables are populated which keeps a count on the total changes made in a day. This mechanism ensures integrity of data passed over a communication channel.

### Interfacing with other Devices

#### Data Logger

Sambandh provides interfaces with data loggers for uploading and downloading data. Data logger can be used in a variety of forms namely

- CMRI (Common Meter Reading Instrument): A device used for tapping all data stored in the memory of electronic meters. In this case, the meter reading and the relevant information are automatically downloaded from the meter to the device
- MRI (Meter Reading Instrument): An instrument used for manual entry of meter readings, which can later be uploaded into the central database. This is basically an electronic device which stores the information contained in a meter book and can be used by the meter reader.

#### Spot Billing Machine



The Hand Held Computer (HHC) or Spot Billing Machine (SBM) is used for generating instant electricity bill at consumer's site. The meter reader is required to load the previous billing information/data of a particular area of coverage from the main computer to the SBM. The typical data consists of information like consumer number, name, address, meter number, previous reading, meter status, arrears, if any, etc.

After pre-loading the consumer data, the meter reader needs to enter the consumer number, current meter reading of the customer and on confirming the validity, the bill will be generated.

The meter reader need not enter the next consumer number, if the operation is in particular order or sequence, he need to enter only the meter reading and status of the meter and then print the bill and serve to the consumer. The process continues till the availability of the consumer records in the SBM. The SBM also generates various summary reports like billing, pending bills list, total services list, etc.

The meter reader needs to upload the transaction data (after issuing the specified area bills) from SBM to base computer station for further process and generation of various reports.

Sambandh provides generic software in language 'C', based on the logic and algorithms provided by the utility. This software is not machine dependent and can be ported to any such devices.

#### **Barcode on all printed documents**

Integration with barcode scanners is provided to print a barcode on bills, protocol sheets, receipts, etc. to uniquely identify each document that is generated by the system.

#### **Data Availability**

The historical data can be made available as and when it is required. Summary data can be stored for long periods. The data can be purged automatically by scheduling it after a specified period. Purging of master data is not permissible. Only transaction data, when required, can be purged. Data can be made available for a prior period by using the techniques of backup, recovery and archival from tapes.

**Interactive Voice Response (IVRS)**

A telephonic inquiry facility can be provided using Interactive Voice Response System (IVRS). It provides miscellaneous services to the applicant/consumer such as inquiry of current status of an application, outstanding arrears, bill payment status, and complaint status.

IVR is an application, which facilitates the inquiry and information vending process. It basically connects the computer system and telephone boxes in such a way that the number pad of telephones can be used to key in the required query.